

Invisacta

The **wide** range of **concealed** hinges

WARNING!

INSTALLATION DEVICE PROTECTED BY PATENT

Only (by) using **INVISACTA**, you can avoid to **cut the cover strips** (in green), thanks to the only 21 mm depth of the hull on the frame side (fig. 1), and **at the same time** install the hinge in the middle of the door thickness (fig. 2) **making the door become both left and right, that means reversible** (fig. 3).



There are unoriginal **INVISACTA** hinges on the market; that don't have the license to use OTLAV patent.

Producing doors as shown herein, with unoriginal **INVISACTA** hinges, **means to make an injury to OTLAV patent rights**, injury which is punishable both civilly and criminally.

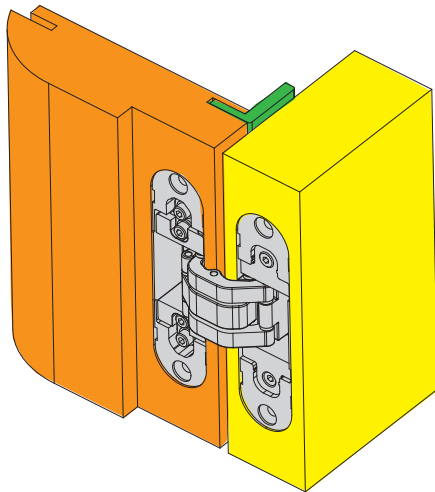

European Patent
EP-B-2719851
16/04/2014

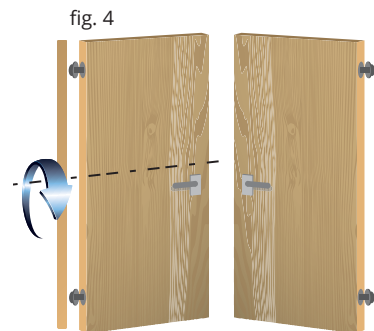
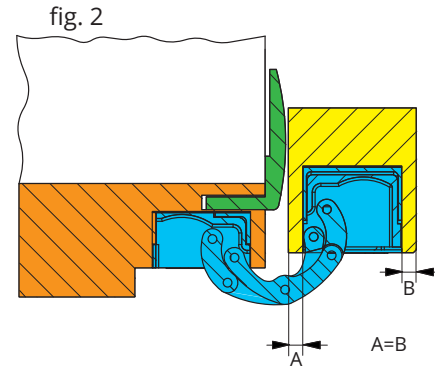
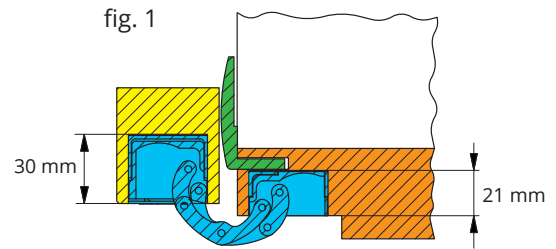

INVISACTA hinge is reversible, which makes the door reversible also vertically (fig. 4).

Since **1956**, thanks to our hinges, more than **1,000,000,000**
doors are moving **in 80 countries** all over the world.



OTLAV S.p.A produces and sells hinges for doors and windows and other accessories for frames.

Founded in 1956 by entrepreneur Angelo Padovan, Otlav has produced **more than 2,2 billion of hinges since 1956.**

Thanks to almost 100 filed patents, Otlav ensures high quality standards and is present with its wide range of products in more than **80 countries worldwide.**

OTLAV new factory was inaugurated in 2007, in Via Angelo Padovan 2 in Santa Lucia di Piave (TV), in an area of 45,000 square meters, 19,500 of which are covered.

Following the opening of the first office in March 1956, OTLAV has nowadays found its perfect location to face the challenges of the new millennium. "OAMH" "Otlav Automatic Material Handling" is a project developed after five years of research and studies all around the world; a technological jewel created by designing at first the best logistical location, and then a subsequent lay out, and eventually the container to cover these structures: an unmistakable technological masterpiece, which is 20 meters high.

Rationalization of space, optimization of logistics and integrated use of automation: all of these account for respectively the flow or transportation of materials and the streaming of information. The goal is to cut costs by making the produced hinges increasingly competitive with an unparalleled level of quality.

OTLAV group companies



In 1990 Otlav creates Myrtus in Maniago (PN), Friuli. The company is specialized in galvanic treatments.



Founded 2002 in Romania is focused on some high-tech producing processes.



QUALITY

As required by European regulations and by Regulation (EU) No. 305/2011 all OTLAV hinges are subjected to stringent resistance tests to check performance both during the design phase and regularly during manufacturing. The I.U.S. (Intensive Use Simulator) is the testing system used in the OTLAV Test Laboratories.

EC Certificates and Performance Declarations

Tests on the hinges are also carried out at external bodies able to certify that the company manufactures according to rigid, systematically monitored production plans and that the products pass the tests envisaged by the standard UNI EN 1935/2004: they are thereby able to issue, if needed, the EC certificate or certify the data provided by OTLAV in the “performance declarations”.



View of the OTLAV test laboratories I.U.S. (Intensive Use Simulator)

IN310190 3D invisible hinge for 120 kg. doors

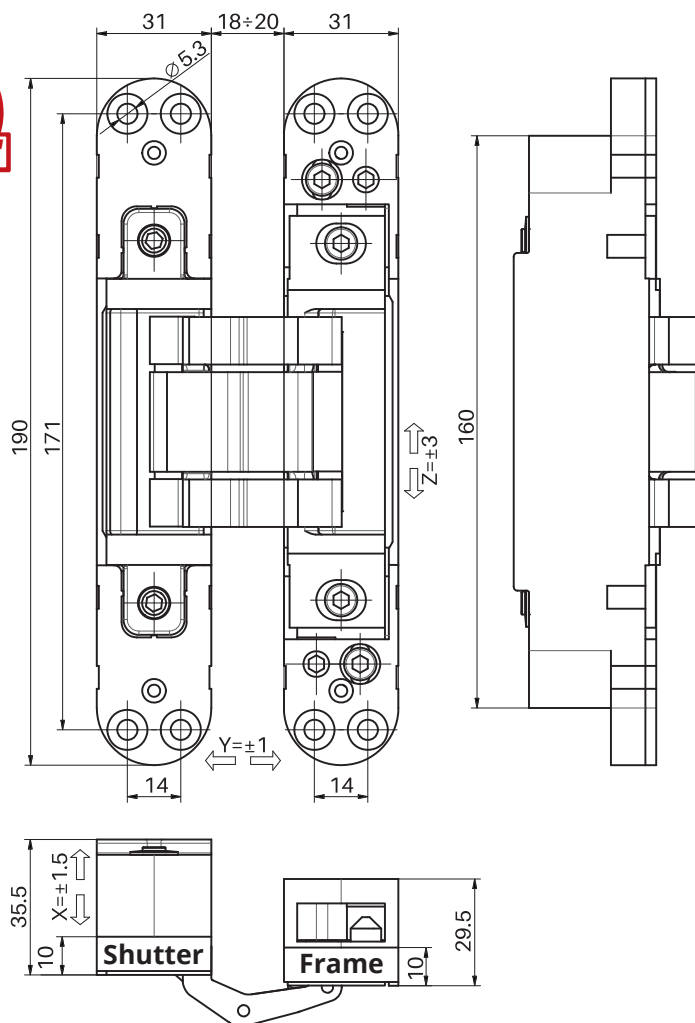

Technical data

Capacity*	120 Kg.
Hinge height	190 mm
Width shutter side	31 mm
Width frame side	31 mm
Depth shutter side	35,5 mm
Depth frame side	29,5 mm
Door opening angle	180°

Side adjustment	± 1,5 mm
Height adjustment	± 3 mm
Depth adjustment	± 1 mm

* Tested with 90x210 cm doors equipped with two hinges. For more information on the number of hinges to be used according to the weight and dimension of the door, please see the loading charts available on the website www.otlav.it.

Technical features

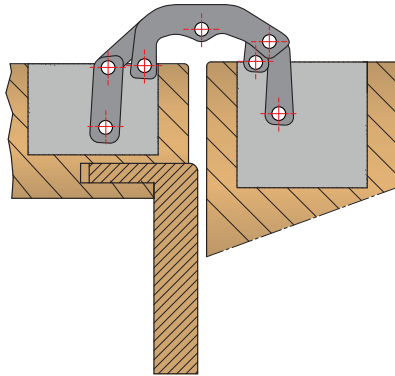

- Movement on **7 junction fulcrums** equipped with bearing in plastic HT with high resistance and long life.
- Equipped with **3-way adjustments** that can be settled by means of just one 4 mm hex-spanner. Once installed, the door has natural sinking, Invisacta hinge allows to set the door back to the start position.
- **The hinge can be fitted with door closing devices.**
- Outer casings protect the inner junction fulcrums against rubble coming from door installation works.
- The clamping screws, placed in the outer casings, are not used for hinge adjustment, therefore they remain stable for a long time.
- **CE certified** - according European Assessment Document 020001-01-0405
- **Fireproof certified 90'** according UNI-EN 1634-1
- Material of levers: aluminum.
- Material of casing: zamak.
- **Caps** available to conceal the screws.

Finishing



IN310190V703
Satinized Silver Plated



IN310190VN03
Satinized Nickel Plated



IN3101909N03
Matt Black Plastified



IN3101909P03
White Matt RAL 9016



IN310190VD03
Polished Chrome



IN310190VO03
Polished Gold

IN570130 3D offset concealed hinge for 60 kg. doors

COMING SOON

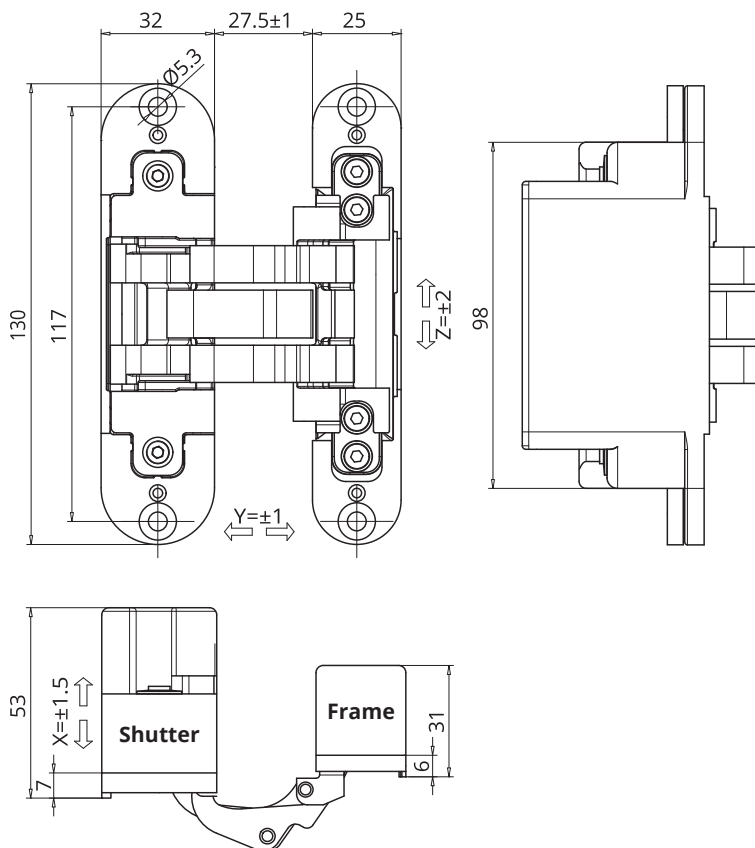
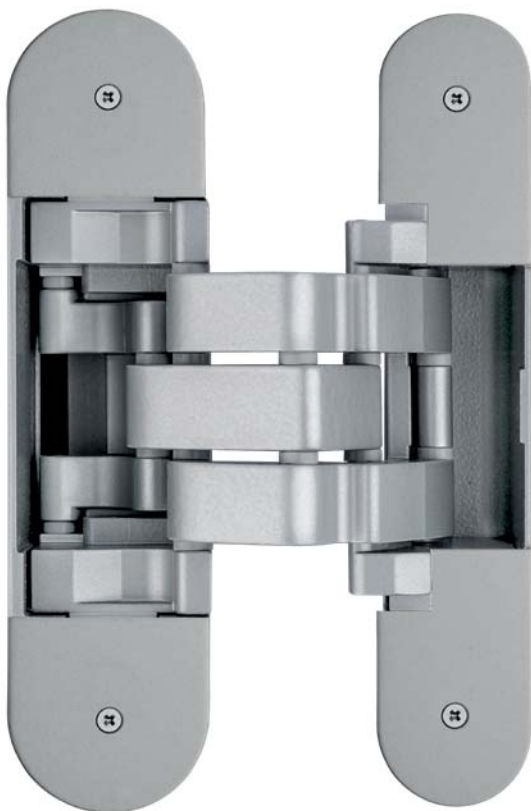

Technical data

Capacity*	60 Kg.
Hinge height	130 mm
Width shutter side	32 mm
Width frame side	25 mm
Depth shutter side	53 mm
Depth frame side	31 mm
Door opening angle	180°

Side adjustment	± 1.5 mm
Height adjustment	± 2 mm
Depth adjustment	± 1 mm

* Tested with 90x210 cm doors equipped with two hinges. For more information on the number of hinges to be used according to the weight and dimension of the door, please see the loading charts available on the website www.otlav.it.

Technical features

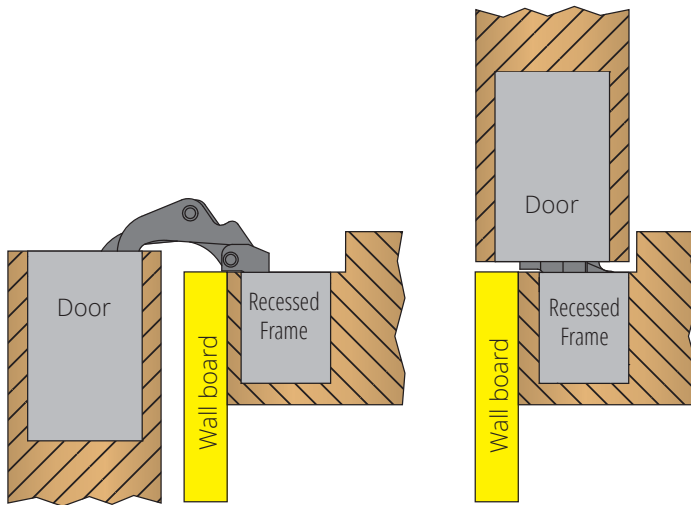

- The hinge is suitable to be installed on doors where **frame is recessed** to accept application of wall board to match.
- Material of casing: zamak.
- Material of levers: aluminum.
- The hinge is reversible, if mounted in the center of the door thickness, allow the **reversibility of the door**, thus enabling the optimization of the stock and logistics at installation.
- Movement on **7 junction fulcrums** equipped with bearing in plastic HT with high resistance and long life.
- Equipped with **3-way adjustments** that can be settled by means of just one hex-spanner. Once installed, the door has natural sinking, Invisacta hinge allows to set the door back to the start position.
- Outer casings protect the inner junction fulcrums against rubble coming from door installation works.
- The clamping screws, placed in the outer casings, are not used for hinge adjustment, therefore they remain stable for a long time.
- **Caps** available to conceal the screws.

Finishing



IN570130V702
Satinized Silver Plated

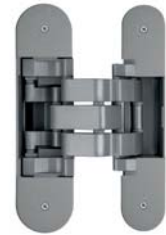

IN570130VN02
Satinized Nickel Plated

IN303120 3D invisible hinge for 80 kg. doors

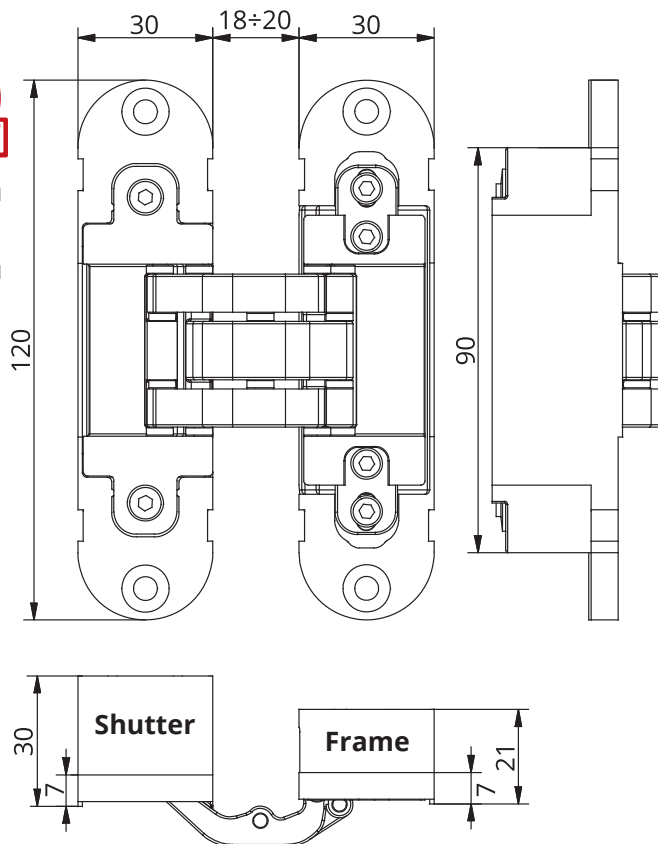

Technical data

Capacity*	80 Kg.
Hinge height	120 mm
Width shutter side	30 mm
Width frame side	30 mm
Depth shutter side	30 mm
Depth frame side	21 mm
Door opening angle	180°

Side adjustment	± 1 mm
Height adjustment	± 2 mm
Depth adjustment	± 1 mm

* Tested with 90x210 cm doors equipped with two hinges. For more information on the number of hinges to be used according to the weight and dimension of the door, please see the loading charts available on the website www.otlav.it.

Technical features

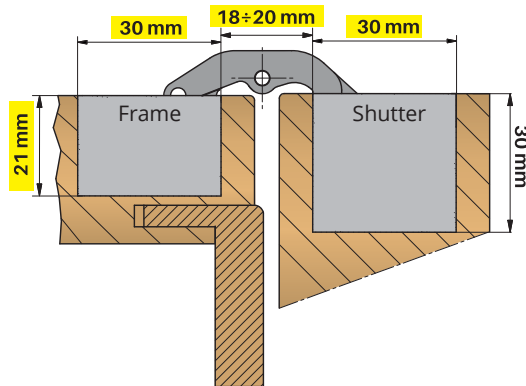

- The hinge is reversible, if mounted in the center of the door thickness, allow the **reversibility of the door**, thus enabling the optimization of the stock and logistics at installation.
- Movement on **7 junction fulcrums** equipped with bearing in plastic HT with high resistance and long life.
- Equipped with **3-way adjustments** that can be settled by means of just one 3 mm hex-spanner. Once installed, the door has natural sinking, Invisacta hinge allows to set the door back to the start position.
- Outer casings protect the inner junction fulcrums against rubble coming from door installation works.
- The clamping screws, placed in the outer casings, are not used for hinge adjustment, therefore they remain stable for a long time.
- **The hinge can be fitted with door closing devices.**
- Material of levers: aluminum.
- Material of casing: zamak.
- **CE certified** - according European Assessment Document 020001-01-0405
- **Fireproof certified 45'** according UNI-EN 1634-1
- **Aluminum caps** available to conceal the screws.

Finishing



Hinge **IN303120V702**
Caps **GC300010J102**
Satinized Silver Plated



Hinge **IN303120VN02**
Caps **GC300010J202**
Satinized Nickel Plated

PATENTED

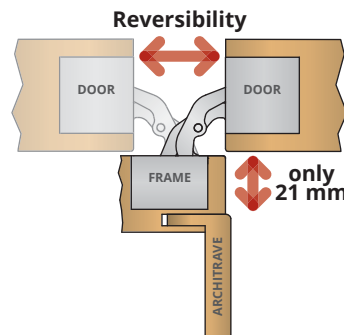

IN303 hinge allows at the same time:
Reversibility of the door with hinge mounted in the center of the door thickness.

No need to cut the architrave thanks to only 21 mm of frame slot depth. Patented EP-B2719851.

IN300120 3D hinge for 60 kg. doors

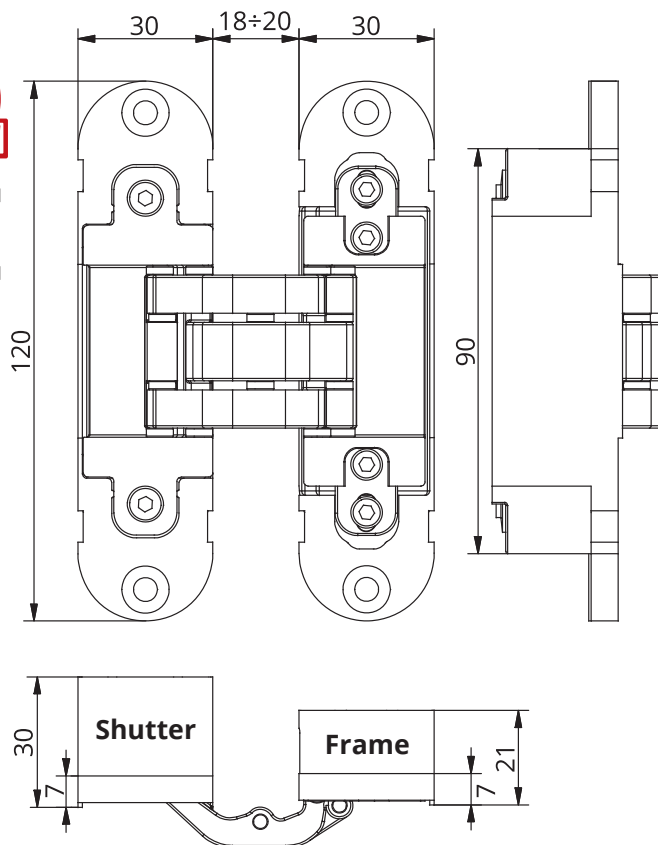

Technical data

Capacity*	60 Kg.
Hinge height	120 mm
Width shutter side	30 mm
Width frame side	30 mm
Depth shutter side	30 mm
Depth frame side	21 mm
Door opening angle	180°

Side adjustment	± 1 mm
Height adjustment	± 2 mm
Depth adjustment	± 1 mm

* Tested with 90x210 cm doors equipped with two hinges. For more information on the number of hinges to be used according to the weight and dimension of the door, please see the loading charts available on the website www.otlav.it.

Technical features

- The hinge is reversible, if mounted in the center of the door thickness, allow the **reversibility of the door**, thus enabling the optimization of the stock and logistics at installation.
- Movement on **7 junction fulcrums** equipped with bearing in plastic HT with high resistance and long life.
- Equipped with **3-way adjustments** that can be settled by means of just one 3 mm hex-spanner. Once installed, the door has natural sinking, Invisacta hinge allows to set the door back to the start position.
- Material of hinge: zamak.
- **The hinge can be fitted with door closing devices.**
- Outer casings protect the inner junction fulcrums against rubble coming from door installation works.
- The clamping screws, placed in the outer casings, are not used for hinge adjustment, therefore they remain stable for a long time.
- Material of hinge: ZAMAK.
- **CE certified** - according European Assessment Document 020001-01-0405
- **Fireproof certified 30'** according UNI-EN 1634-2.
- **Aluminum caps** available to conceal the screws.

PATENTED

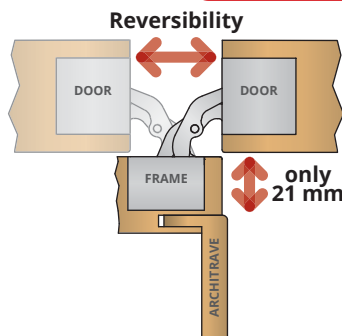

IN300 hinge allows at the same time:

Reversibility of the door with hinge mounted in the center of the door thickness.

No need to cut the architrave thanks to only 21 mm of frame slot depth. Patented EP-B2719851.

Finishing



Hinge **IN300120V702**
Caps **GC300010J102**
Satinized Silver Plated



Hinge **IN300120VN02**
Caps **GC300010J202**
Satinized Nickel Plated



Hinge **IN3001209P02**
Caps **GC3000109P02**
White Matt RAL 9016



Hinge **IN300120H004**
Caps **GC300010J102**
Zinc Plated



Hinge **IN300120B002**
Caps **GC3000109R02**
Bronze Plated



Hinge **IN300120802**
Caps **GC300010J005**
Polished Gold



Hinge **IN3001209N02**
Caps **GC3000109N02**
Matt Black Plastified

IN305120 3D invisible hinge for 40 kg. doors

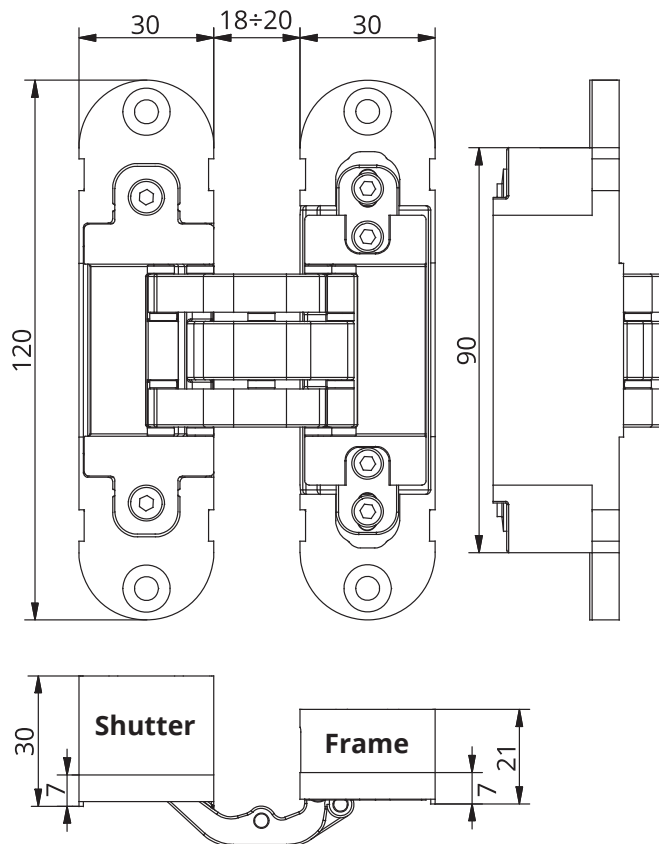

Technical data

Capacity*	40 Kg.
Hinge height	120 mm
Width shutter side	30 mm
Width frame side	30 mm
Depth shutter side	30 mm
Depth frame side	21 mm
Door opening angle	180°

Side adjustment	± 1 mm
Height adjustment	± 2 mm
Depth adjustment	± 1 mm

* Tested with 90x210 cm doors equipped with two hinges. For more information on the number of hinges to be used according to the weight and dimension of the door, please see the loading charts available on the website www.otlav.it.

Technical features

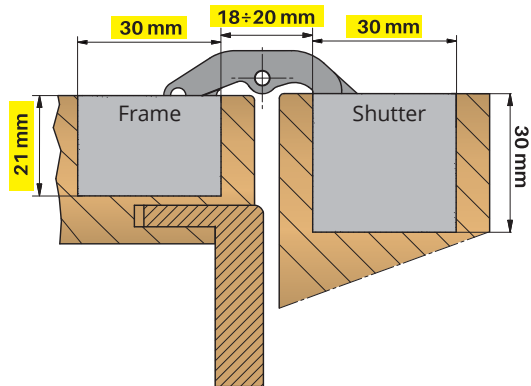

- The hinge is reversible, if mounted in the center of the door thickness, allow the **reversibility of the door**, thus enabling the optimization of the stock and logistics at installation.
- Movement on **7 junction fulcrums** equipped with bearing in plastic HT with high resistance and long life.
- Equipped with **3-way adjustments** that can be settled by means of just one 3 mm hex-spanner. Once installed, the door has natural sinking, Invisacta hinge allows to set the door back to the start position.
- Material of hinge: ZAMAK.
- Material of casing: thermoplastic polymer.
- Outer casings protect the inner junction fulcrums against rubble coming from door installation works.
- The clamping screws, placed in the outer casings, are not used for hinge adjustment, therefore they remain stable for a long time.
- **Aluminum caps** available to conceal the screws.

Finishing



Hinge **IN305120V702**
Caps **GC300010J102**
Satinized Silver Plated



Hinge **IN305120VN02**
Caps **GC300010J202**
Satinized Nickel Plated



Hinge **IN305120H002**
Caps **GC300010J102**
Zinc Plated

PATENTED

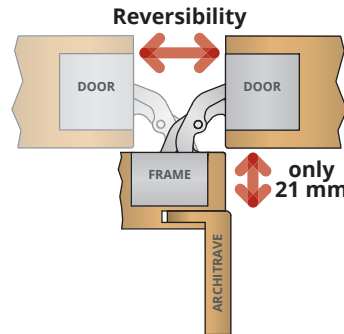

IN305 hinge allows at the same time:

Reversibility of the door with hinge mounted in the center of the door thickness.

No need to cut the architrave thanks to only 21 mm of frame slot depth. Patented EP-B2719851.

IN230120 3D invisible hinge for 60 kg. doors

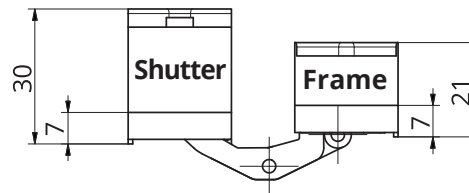
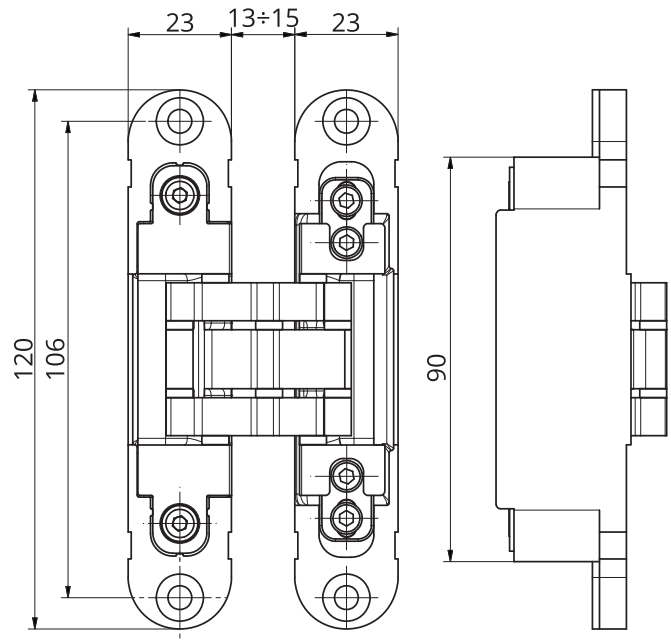

Technical data

Capacity*	60 Kg.
Hinge height	120 mm
Width shutter side	23 mm
Width frame side	23 mm
Depth shutter side	30 mm
Depth frame side	21 mm
Door opening angle	180°

Side adjustment	± 1 mm
Height adjustment	± 2 mm
Depth adjustment	± 1 mm

* Tested with 90x210 cm doors equipped with two hinges. For more information on the number of hinges to be used according to the weight and dimension of the door, please see the loading charts available on the website www.otlav.it.

Technical features

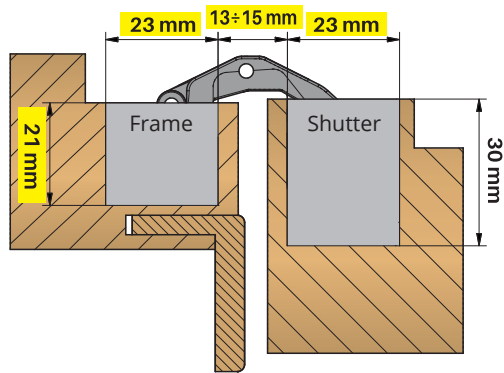

- A **21 mm depth slot** on the frame side makes it unique and enables its perfect integration in reduced spaces. No need to cut the architrave which can be flush mounted.
- Movement on **7 junction fulcrums** equipped with bearing in plastic HT with high resistance and long life.
- Equipped with **3-way adjustments** that can be settled by means of just one 3 mm hex-spanner. Once installed, the door has natural sinking, Invisacta hinge allows to set the door back to the start position.
- The hinge is reversible.
- **The hinge can be fitted with door closing devices.**
- Outer casings protect the inner junction fulcrums against rubble coming from door installation works.
- The clamping screws, placed in the outer casings, are not used for hinge adjustment, therefore they remain stable for a long time.
- Material of hinge: ZAMAK.
- **CE certified** - according European Assessment Document 020001-01-0405
- **Fireproof certified 30'** according UNI-EN 1634-2
- **Aluminum caps** available to conceal the screws.

Finishing



Hinge **IN230120V702**
Caps **GC230010J102**
Satinized Silver Plated



Hinge **IN230120H004**
Caps **GC230010J102**
Zinc Plated

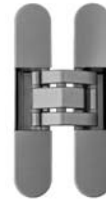

Hinge **IN230120VN02**
Caps **GC230010J202**
Satinized Nickel Plated



Hinge **IN230120B002**
Caps **GC2300109R02**
Bronze Plated



Hinge **IN2301209P02**
Caps **GC2300109P02**
White Matt RAL 9016



Hinge **IN230120802**
Caps **GC230010JO05**
Polished Gold



Hinge **IN2301209N02**
Caps **GC2300109N02**
Matt Black Plastified

IN235120 3D invisible hinge for 40 kg. doors

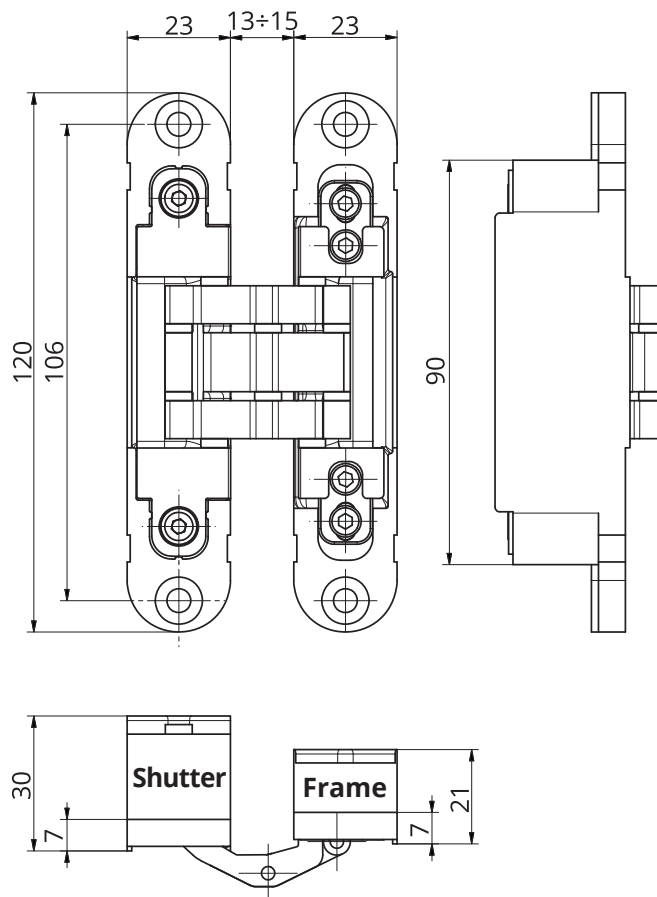

Technical data

Capacity*	40 Kg.
Hinge height	120 mm
Width shutter side	23 mm
Width frame side	23 mm
Depth shutter side	30 mm
Depth frame side	21 mm
Door opening angle	180°

Side adjustment	± 1 mm
Height adjustment	± 2 mm
Depth adjustment	± 1 mm

* Tested with 90x210 cm doors equipped with two hinges. For more information on the number of hinges to be used according to the weight and dimension of the door, please see the loading charts available on the website www.otlav.it.

Technical features

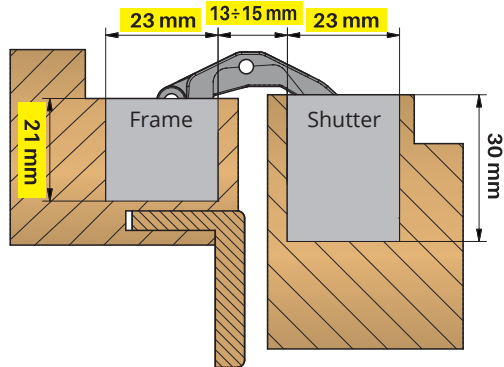

- A **21 mm depth slot** on the frame side makes it unique and enables its perfect integration in reduced spaces. No need to cut the architrave which can be flush mounted.
- Movement on **7 junction fulcrums** equipped with bearing in plastic HT with high resistance and long life.
- Equipped with **3-way adjustments** that can be settled by means of just one 3 mm hex-spanner. Once installed, the door has natural sinking, Invisacta hinge allows to set the door back to the start position.
- Material of hinge: ZAMAK.
- Material of casing: thermoplastic polymer.
- The hinge is reversible.
- Outer casings protect the inner junction fulcrums against rubble coming from door installation works.
- The clamping screws, placed in the outer casings, are not used for hinge adjustment, therefore they remain stable for a long time.
- **Aluminum caps** available to conceal the screws.

Finishing



Hinge **IN235120V704**
Caps **GC230010J102**
Satinized Silver Plated



Hinge **IN235120H006**
Caps **GC230010J102**
Zinc Plated



Hinge **IN235120VN04**
Caps **GC230010J202**
Satinized Nickel Plated



Hinge **IN2351209P14**
Caps **GC2300109P02**
White Matt RAL 9016

IN232120 invisible hinge for 30 kg. doors

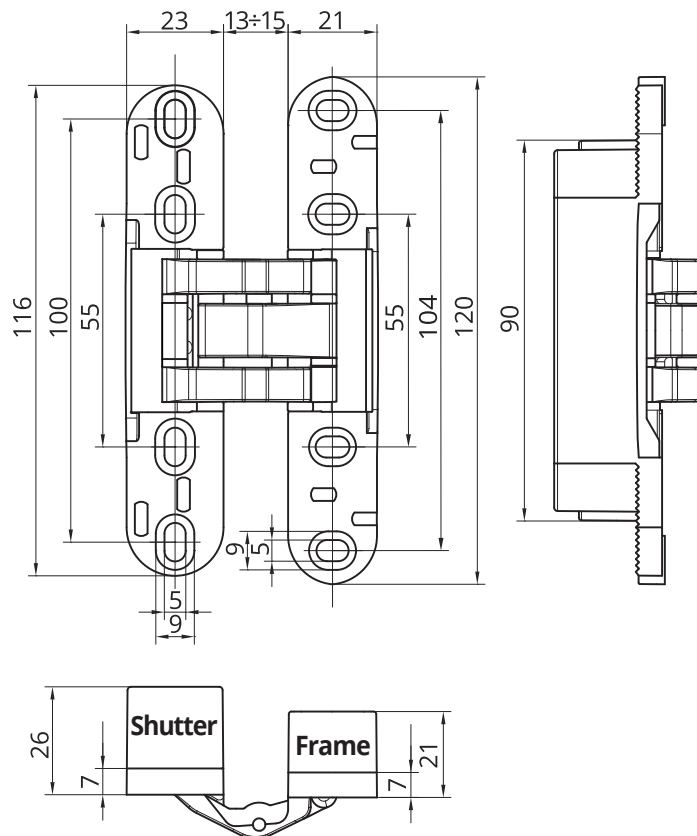

Technical data

Capacity*	30 Kg.
Depth shutter side	26 mm
Depth frame side	21 mm
Door opening angle	180°
Height adjustment	± 2 mm
Depth adjustment	± 1 mm

* Tested with 90x210 cm doors equipped with two hinges. For more information on the number of hinges to be used according to the weight and dimension of the door, please see the loading charts available on the website www.otlav.it.

Technical features

- A 21 mm depth slot on the frame side makes it unique and enables its perfect integration in reduced spaces. No need to cut the architrave which can be flush mounted.
- Material of levers: zamak.
- Material of casing: thermoplastic polymer.
- Equipped with caps to conceal the screws.
- The hinge can be fitted right and left.
- Movement on 7 junction fulcrums equipped with bearing in plastic HT with high resistance and long life.
- Equipped with height and depth adjustments.
- Compatible with millings of IN230120 and IN235120 hinges.



IN232120H003
A model



IN232120H006
B model

Side adjustment

The hinge marked with the letter "A" must be installed at the top; the hinge marked with the letter "B" must be installed at the bottom.

Once installed, it is natural for the door to drop slightly. If the IN232 hinges are installed correctly, it is possible to restore the door to its optimal position thanks to the difference between model "A" and "B".

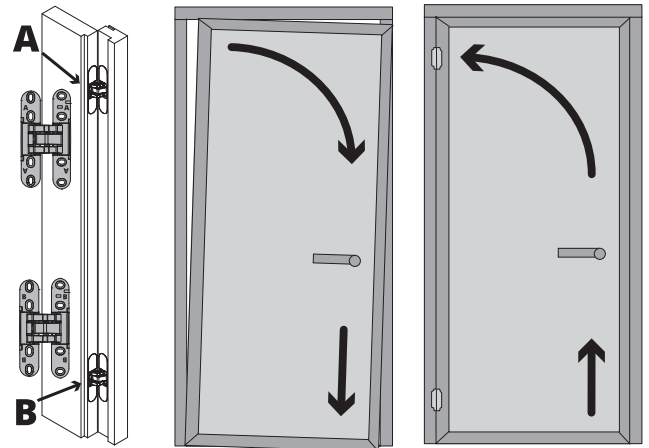

IN301090 invisible hinge for 40 kg. doors

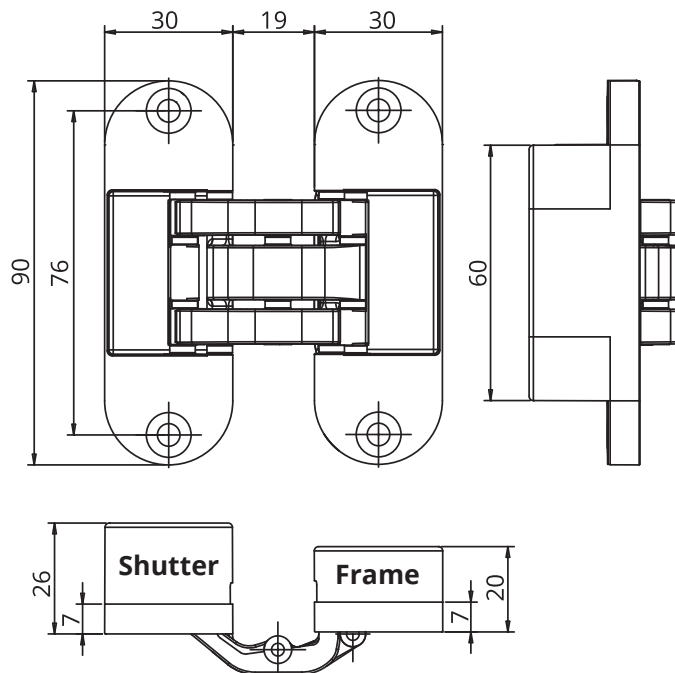

Technical data

Capacity*	40 Kg.
Hinge height	90 mm
Width shutter side	30 mm
Width frame side	30 mm
Depth shutter side	30 mm
Depth frame side	21 mm
Door opening angle	180°

* Tested with 90x210 cm doors equipped with two hinges. For more information on the number of hinges to be used according to the weight and dimension of the door, please see the loading charts available on the website www.otlav.it.

Technical features

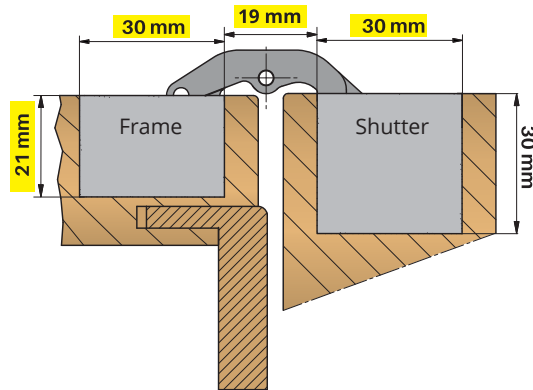

- A **21 mm depth slot** on the frame side makes it unique and enables its perfect integration in reduced spaces. No need to cut the architrave which can be flush mounted.
- Material of hinge: ZAMAK.
- The hinge is reversible, if mounted in the center of the door thickness, allow the **reversibility of the door**, thus enabling the optimization of the stock and logistics at installation.
- Movement on **7 junction fulcrums** equipped with bearing in plastic HT with high resistance and long life.
- Outer casings protect the inner junction fulcrums against rubble coming from door installation works.
- The clamping screws, placed in the outer casings, are not used for hinge adjustment, therefore they remain stable for a long time.

Finishing



IN301090B002
Bronze plated



IN301090V702
Satinized silver plated

PATENTED

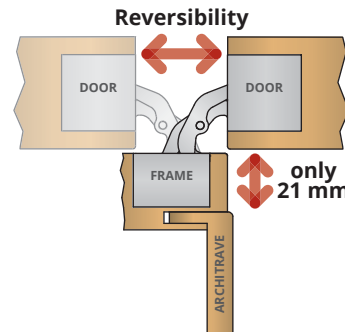

IN301 hinge allows at the same time:
Reversibility of the door with hinge mounted in the center of the door thickness.

No need to cut the architrave thanks to only 21 mm of frame slot depth. Patented EP-B2719851.

CI335150N035 plate hinge for 40 kg. doors

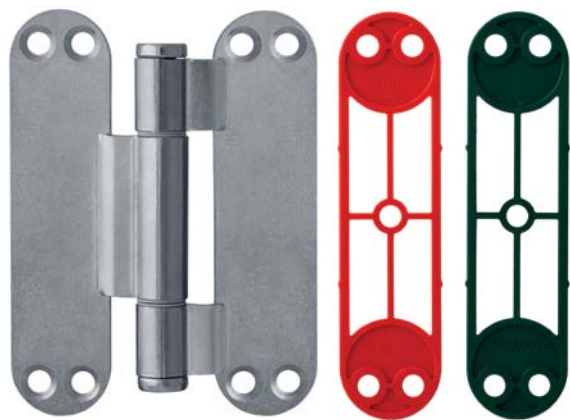

Technical features

- The hinge is suitable to be installed on doors and frames with IN300, IN303 and IN305 millings.
- The hinge can be fitted right and left.
- Equipped with spacers that allows to prevent the natural sinking of the door.
- Kit composed by: 3 hinges, 4 green spacer, 4 red spacer and 24 screws

Technical data

Capacity* 40 Kg.

* Tested with 90x210 cm doors equipped with three hinges. For more information on the number of hinges to be used according to the weight and dimension of the door, please see the loading charts available on the website www.otlav.it.

Finishing

Nickel plated

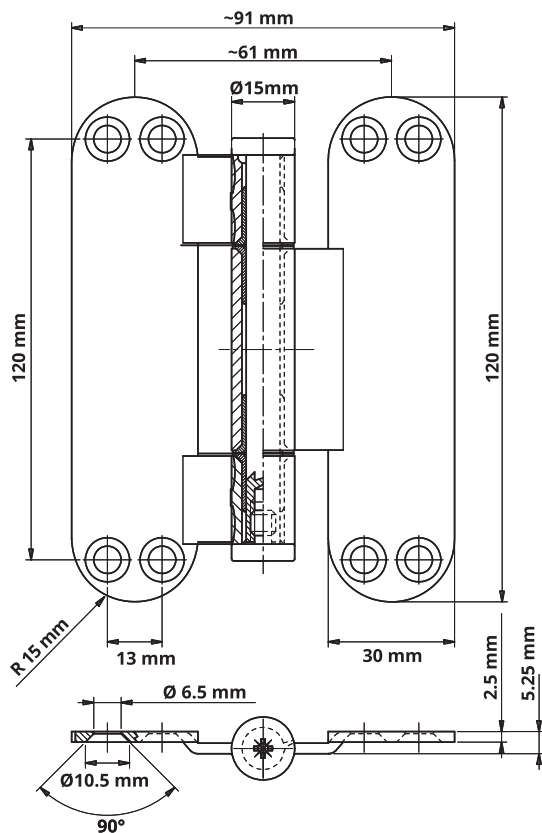

Positioning

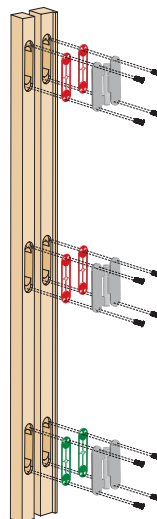

Accessories

Plate



JR52
Fixing plate for IN310



NP120040H502
Plate for IN300 and IN303 hinges

NP120040H504
Plate for IN230 and IN235 hinges



PP02
Shim to set up the plate NP120

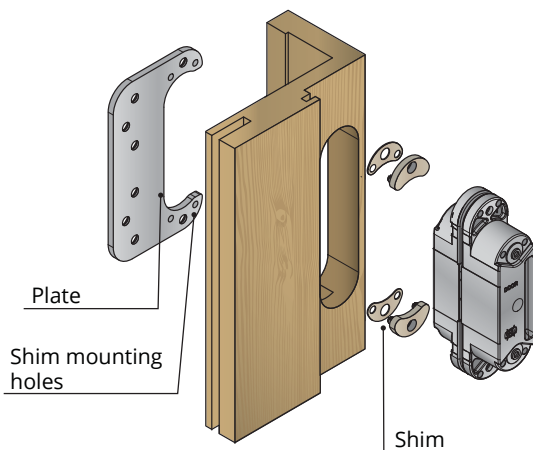

Jigs



MU230120G002
Aluminium jig for IN230, IN232 and IN235 hinges

MU300120G002
Aluminium jig for IN300 and IN303 hinges

MU310190G002
Aluminium jig for IN310 hinges



MUINV500G004
Nylon jig for IN230, IN232 and IN235 hinges

MUINV500G002
Nylon jig for IN300 and IN303 hinges

MUINV500G006
Nylon jig for IN310 hinges

Adjustable door alignment device

- The device allows to keep the shutter aligned to the frame, avoiding in this way door deformities.
- Equipped with adjustable tension of the door jamb.
- Aluminum caps available to conceal the screws.

AI300 Compatible with millings of IN300, IN305 and IN303 hinges

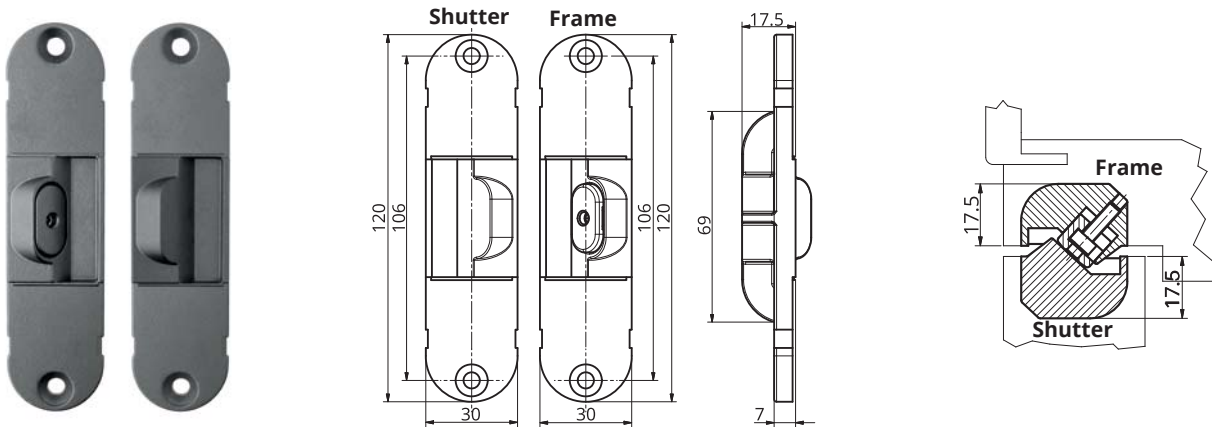

AI230 Compatible with millings of IN230 and IN235 hinges

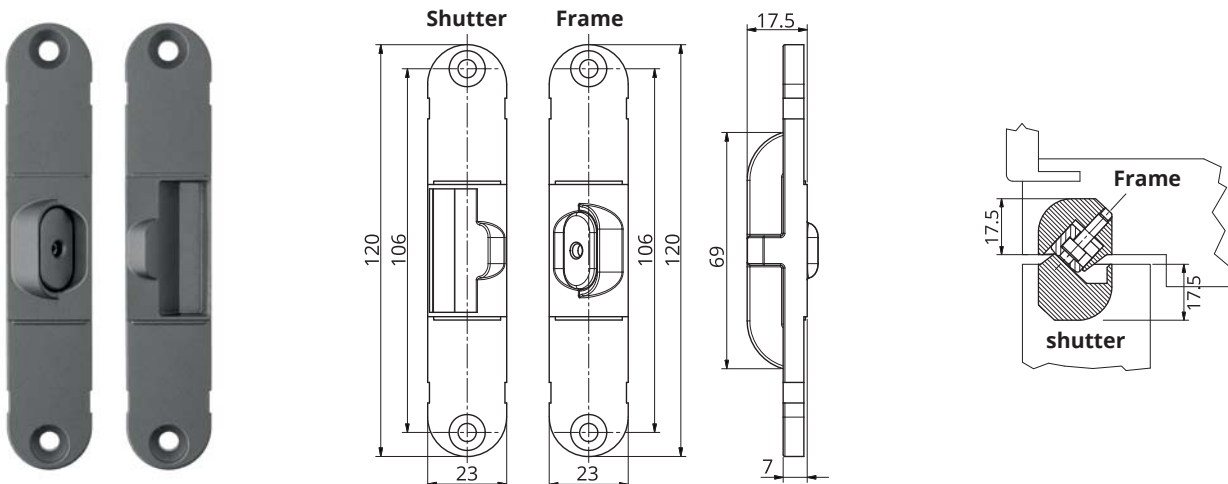

COMPATIBILITY

Same millings, different hinges.

millings
23x120 mmh

IN230

Doors up to 60 kg.



IN235

Doors up to 40 kg.



IN232

Doors up to 30 kg.

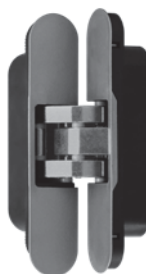

AI230

door alignment device



millings
30x120 mmh

IN303

Doors up to 80 kg.



IN300

Doors up to 60 kg.



IN305

Doors up to 40 kg.



CI335

Doors up to 40 kg.



AI300

door alignment device

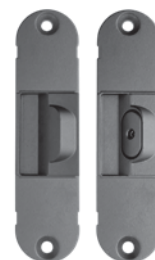

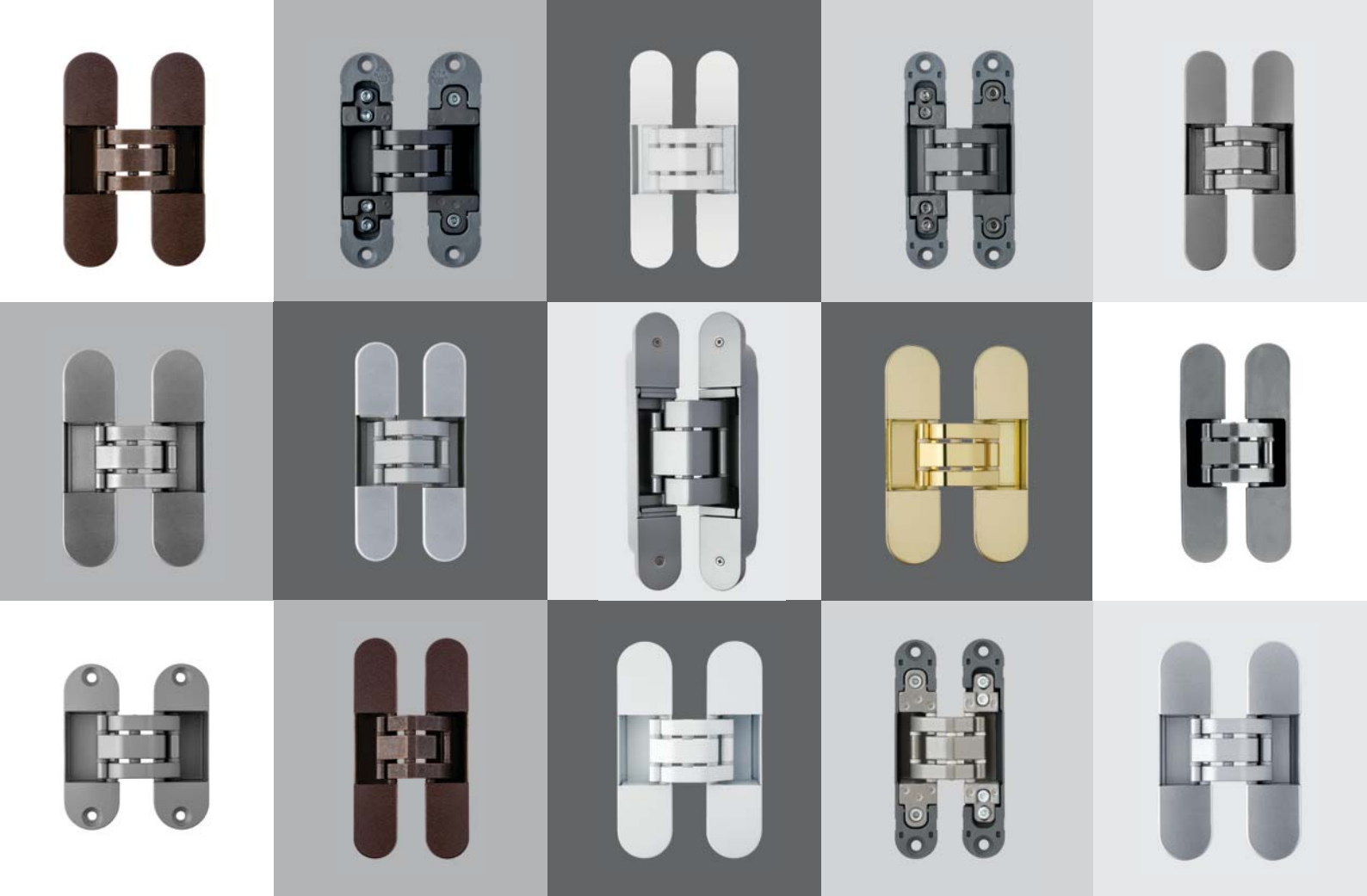

Via Angelo Padovan, 2
 31025 - Santa Lucia di Piave (TV) - Italy
 tel. +39 0438 4611 fax +39 0438 439252
www.otlav.it info@otlav.it

Follow us:

